



Kula

the integrated amplifier



User's Manual

Mola Mola

Kattegat 8
9723 JP Groningen
The Netherlands
+31 50 526 4993
info@mola-mola.nl
www.mola-mola.nl

Please read this manual before operating the device

Packing list

Your product was shipped with the items checked below. Please verify that you find all items mentioned in this list before you start setting up:

Item	Qty	Shipper's signature
Integrated Amplifier	1	
Power Cord	1	
Standard Remote Control Unit		
Premium Remote Control Unit		
Phono Option (internal)		
DAC Option (internal)		

This Mola Mola product has no user serviceable parts inside. Opening and/or making changes to the unit by any other than Mola Mola approved service engineers voids the warranty.

Welcome

First off, congratulations! With the purchase of this product you have joined a growing community of audiophiles who value truthful sound reproduction and who consider neutral and transparent electronics a cornerstone in this pursuit. We at Mola Mola made it our primary goal to build electronics capable of passing a signal with no discernible change at all. Amplifiers make the signal bigger, converters turn the signal from a digital representation into an analogue one. In all these processes we strive to add nothing and to remove nothing.

Through our work designing professional audio equipment we have collected extensive knowledge of how to achieve total freedom from colouration without having to resort to minimalist circuitry. This allows us to build products that are purist without cutting back functionality. So we decided that our integrated amplifier should be complete. *Very* complete.

The basic Kula Integrated Amplifier has an extremely transparent gain stage and a programmable routing matrix. The chassis has ample room to fit in optional extras, most notably a DAC and a phono stage.

The 6 preset buttons are programmable via Bluetooth to access any combination of channel, processing and routing. In a system with mainly digital sources, the preset buttons would be programmed to select between them. Vinyl lovers on the other hand might want to use several buttons to select the same turntable but with different EQ settings to suit their large collection of historic LP's. All five inputs are switchable between XLR and floating RCA connections, and all can be assigned as either phono or line.

We wish you a lifetime of musical enjoyment with this product and thank you for your custom.

Mola Mola Team

Table of contents

Important Safety Instructions	1
Connections & Controls	3
Rear	3
Front	4
DIGIN module (optional)	4
Setting Up	5
Installation	5
Connection	5
Basic operation	7
Factory Preset Mode	7
Front Panel Operation	7
Premium IR Remote Control Operation	8
Standard IR Remote Control Operation	8
Android® and iOS®	8
Advanced Control and Programming	9
Signal Path	9
Programmability	10
The Mola Mola Remote app	11
Setting Up and Controlling the Phono Stage	22
Roon	26
DAC	28
Drivers and Updates	29
Troubleshooting	30
Audio performance data	31
Audio performance data Phono Stage	32
Audio performance data DAC	33
Technical data	34
Annex I: RC5 Codes	35
Annex II: Standard Remote Control Unit	36
Revision History	37

List of tables

Table 1: Rear panel overview	3
Table 2: Front panel overview.....	4
Table 3: DIGIN module overview	4
Table 4: Digital source overview.....	28
Table 5: Audio Performance Data.....	31
Table 6: Audio performance data Phono Stage	32
Table 7: Audio performance data DAC.....	33
Table 8: Technical Data	34
Table 9: RC5 Codes.....	35

List of figures

Figure 1: Rear panel overview	3
Figure 2: Front panel overview.....	4
Figure 3: DIGIN module overview	4
Figure 4: Sketch of the internal signal path.....	9
Figure 5: Pull down to scan for devices.	11
Figure 6: Discovered devices.	11
Figure 7: Type in new name and click Add device.	12
Figure 8: The start-up page.	12
Figure 9: Swipe left to show disconnect and remove buttons.	13
Figure 10: Home Page, Preset 6 is selected.....	14
Figure 11: Preset Page, input 1 is selected.	16
Figure 12: About Page.	19
Figure 13: About Page.	21
Figure 13: Phono Stage Page.	22
Figure 14: List of Phono Stage EQ Curves.	25
Figure 15: The Kula will show up on the Audio settings page in Room	26
Figure 16: Fill in Zone Name.....	26
Figure 17: Click on Configure Device to go to the Kula webpage.....	27
Figure 18: The Kula webpage	27
Figure 19: Firmware update tool.	29

Important Safety Instructions

Throughout this document, some aspects of operation that have a potential impact on safety or reliability are noted with the words “Warning” and “Caution”. Take particular care reading and understanding these items. Paragraphs marked with “Warning” explain safety measures required to maintain your personal safety. Paragraphs marked with “Caution” pertain to danger to the equipment itself or to connected equipment. Please follow these precautions when using this product:

1. Read these instructions.
2. Keep these instructions.
3. Follow all instructions.
4. Heed all warnings.
5. Install in accordance with the manufacturer's instructions.
6. Use only attachments or accessories specified by the manufacturer.
7. **WARNING:** Dangerous voltage is inside this apparatus. Opening is only allowed by qualified service personnel.
8. **WARNING:** Do not defeat the safety purpose of the safety earth connection. Use the provided three-prong power cord to ensure the product is connected to safety earth. If the provided mains cord does not fit your outlet, consult an electrician for replacement of the obsolete outlet.
9. Protect the power cord from being walked on or pinched, particularly at plugs, convenience receptacles, and the point where they exit from the apparatus.
10. Unplug this apparatus during lightning storms or when unused for long periods of time.
11. **WARNING:** Do not use this apparatus near water. Do not expose the apparatus to dripping or splashing. Do not place objects filled with liquids (flower vases, drink cans, coffee cups, etc) on the apparatus. Do not use this apparatus out of doors.
12. **WARNING:** Clean only with a dry, soft, lint-free cloth. Do not spray any liquid cleaner onto the cabinet, as this may lead to dangerous shocks or malfunction.
13. **CAUTION:** This device runs slightly warm when operated normally. Operate in a normally ventilated area.

14. CAUTION: Do not install near any heat sources such as radiators, heat registers, stoves, or other apparatus (including amplifiers) that produce heat. Avoid exposure to direct sunlight.
15. Use only with a cart, stand, bracket, or table designed for use with audio or music equipment. In any installation, make sure that injury or damage will not result from cables pulling on the apparatus and its mounting.
16. Refer all servicing to qualified service personnel. Servicing is required when the apparatus has been damaged in any way, such as when the power-supply cord or plug is damaged, liquid has been spilled or objects have fallen into the apparatus, the apparatus has been exposed to rain or moisture, does not operate normally, or has been dropped.
17. WARNING: To reduce the risk of fire or electric shock, do not expose this apparatus to rain or moisture.

Connections & Controls

Rear

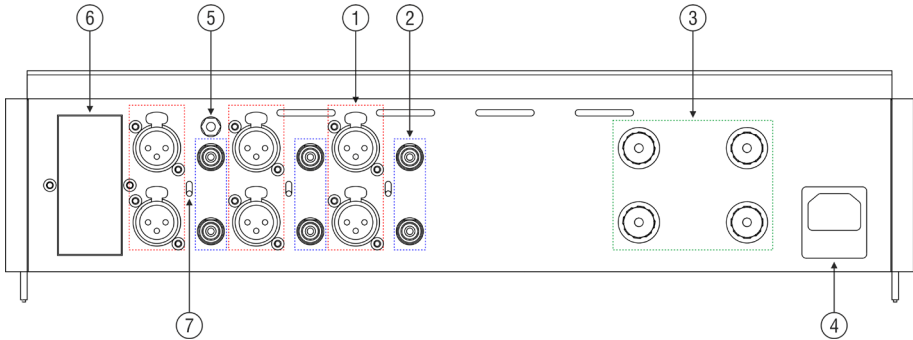

Figure 1: Rear panel overview

#	Function	Notes
1	Analogue inputs, balanced	3 stereo pairs
2	Analogue inputs, unbalanced	3 stereo pairs
3	Speaker Outputs, single ended	1 pair of binding posts
4	Mains power input	-
5	Chassis ground terminal	For turntable grounding
6	Option module void cover	-
7	(Un)Balanced toggle switch	One for each input pair

Table 1: Rear panel overview

Front

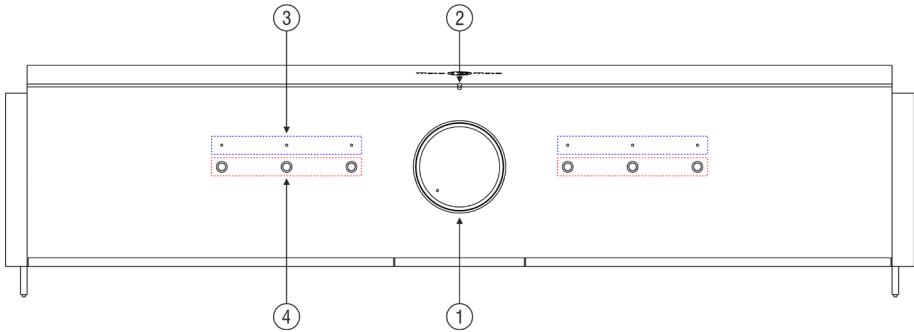

Figure 2: Front panel overview

#	Function	Notes
1	Volume control knob	With indicator LED
2	Power LED	1 LED, white or dim red
3	Preset indicator LED	6 LEDs, white
4	Presets	6 push buttons

Table 2: Front panel overview

DIGIN module (optional)

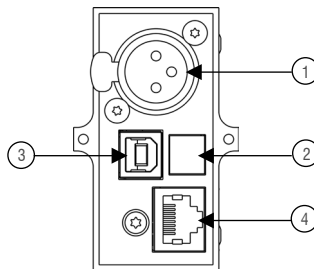

Figure 3: DIGIN module overview

#	Function	Notes
1	AES/EBU	
2	Optical (Toslink)	
3	USB type B	USB audio + firmware updates
4	Network	Only functional when network module is fitted

Table 3: DIGIN module overview

Setting Up

Installation

This product relies on free convection of air along the sides and top for cooling. Avoid placing magazines, books or other objects on top of the product as this acts as thermal insulation. Installation inside a cupboard is permissible provided at least 30cm (12") of free space above the product and 10cm (4") around the sides is respected. Operation in closer quarters requires some provision of forced convection (fan) to be installed inside the cupboard.

Connection

CAUTION: Whenever you are plugging or unplugging cables, make sure that the volume control is turned fully down. Failure to take this precaution may result in pops or bangs in the loudspeaker. Use properly shielded interconnects with reliable connectors.

AC Power Input

Connect the supplied power cord to the AC input receptacle on the rear panel. Do not connect the power cord until all the audio input and output connections have been made.

It is usually best to plug the product directly into a wall outlet. Avoid the use of extension cords. A heavy duty multi-tap power outlet strip may be used if it and the wall outlet are rated to handle the total current demanded by the components connected to it.

Your Kula has a universal input power supply, allowing it to operate anywhere from 90V to 240V mains.

If you are going to be away from home for an extended period of time such as a month-long vacation, it is a sensible precaution to unplug electronic equipment. Do the same as a precautionary measure during thunderstorms. No amount of surge protection or mains filtering will save your equipment from a lightning strike in the backyard.

Initialisation procedure

The initialisation procedure only applies when the Kula has the DAC module and network module fitted. The initialisation procedure will automatically start after the mains power has been applied will take about one minute. At the start and end of this procedure you might hear some clicking sounds. During the initialisation procedure the Kula will become visible in Roon if it is connected to your network. The Kula will also remain visible in Roon during standby mode. You can power up the Kula during the initialisation procedure and start

listening to analog sources right away. You can start listening to digital sources one minute after the mains power has been applied.

Input Connections

Your Kula accepts both RCA and XLR type connectors. If your sources have both RCA and XLR outputs, it is exceedingly likely that using the XLR connection sounds best. Depending on which you choose, set the toggle switch to the corresponding input.

Output connections

One pair of high grade rhodium-plated binding posts are provided which accepts both banana and spade connectors.

Grounding Post

Connect any turntable ground wires to the grounding post to minimize the chances of capacitively induced hum on the phono cartridge from the turntable.

Basic operation

Factory Preset Mode

Your Kula comes factory-programmed as a simple line amplifier. In this mode:

- The leftmost button selects the leftmost source (source 1) and so on and the rightmost button is used for Room (if the DAC option is fitted). So for now, think of the preset button simply as input select buttons.
- XLR/RCA selection is determined by the toggle switches.

Should you wish to return your Kula to its factory-programmed state, you can do so by holding down the two buttons directly besides the volume control for one second or more. It makes good sense to do this if this is a device you are loaning for evaluation and it was sent to you directly by a previous user.

If like most users you only have a handful of line-level sources you can just go ahead and use the device in this way.

Front Panel Operation

Powering Up

So long as mains power is applied the power LED can be in two states: on or standby. In standby mode it will light up a dim red (barely visible in daylight, bright red standby LEDs lighting up the room at night is a pet peeve of the designer). Push any of the 6 buttons to wake up the amp. The power LED lights up white and the preset you have just pushed will be engaged (as indicated by the LED above the button).

Selecting Inputs

The preset indicator LED lights up solid when the integrated amplifier is passing signal and blinks when it is muted. The amp mutes temporarily for a moment after powering up or after changing presets.

Muting

You can also make your Kula mute by pushing the currently selected preset button. Push again or change presets to unmute.

Powering Down

You can place the Kula in standby mode by holding any of the 6 buttons until the device powers down (about 1 second).

Premium IR Remote Control Operation

The group of six buttons on the remote control mirrors the front panel buttons. Pushing any of them will power the device on and/or engage the associated preset and/or mute the unit. The top button acts as mute/standby button and does the exact same as the preset buttons except it does not switch presets. This is mainly useful because the remote control unit obviously does not have LEDs to indicate which preset is engaged and sometimes you just want to mute the device regardless of what was playing.

The volume up/down buttons operate as they do anywhere else. The LED on the volume knob will come on to provide easy visual feedback of the volume setting.

Standard IR Remote Control Operation

The standard-issue RC unit works slightly differently. The button in the middle of the quadrants turns the Kula on or off (hold 1 second for off). Press this button once for mute or unmute. Pushing on the left and right quadrants of the ring cycles through the 6 presets. The top and bottom quadrants control the volume. The two lower buttons are not used.

Android® and iOS®

Your Kula is fitted with a Bluetooth® module to allow access with a mobile device. To use this feature, install the Mola Mola Remote app from the App Store or Play store.

The home page shows preset buttons and volume control. Other pages are used for advanced control and programming. They are explained in the Mola Mola remote section.

Powering Up and Down

The stand-by logo in the top left corner acts as power button.

Volume control

Move the slider at the bottom of the home page to change volume. The + and – buttons can also be used to adjust the volume in small steps. Click on the speaker indicator to mute or unmute.

Mute

Click on the speaker indicator to mute or unmute. The speaker indicator and volume slider bar will turn red when muted.

Advanced Control and Programming

The factory preset only operates the most basic features of your integrated amplifier. The architecture is much more powerful, as the signal path diagram shows.

Signal Path

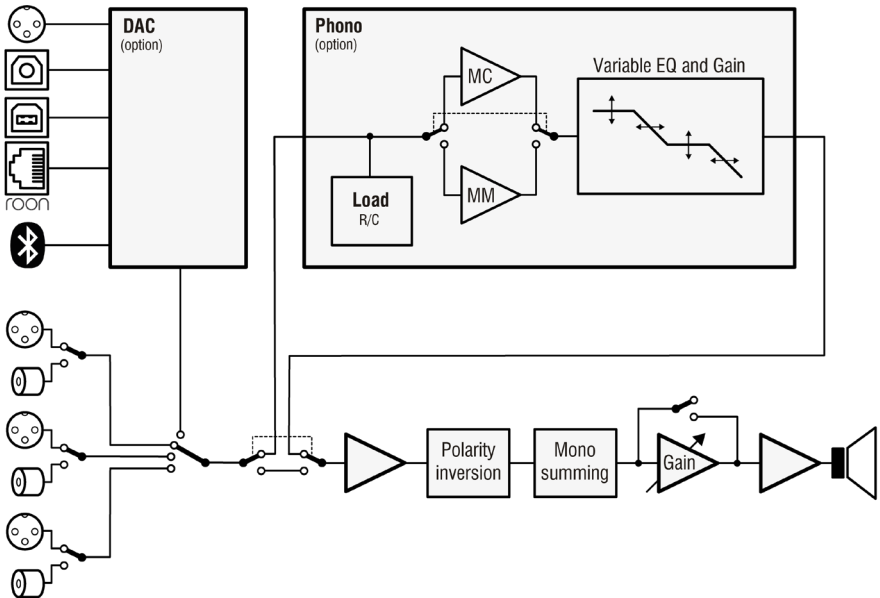

Figure 4: Sketch of the internal signal path.

Everything that can be switched or changed in the above diagram is under software control:

- XLR/RCA switching
- Source selection
- Routing of any input through the optional phono stage
- Variable loading, gain and EQ of the optional phono stage
- Polarity inversion of left, right or both
- Mono summing

- Volume
- Balance (independent control of left/right volume)

Programmability

Every thinkable combination of routing and processes can be rolled together for direct access through any of the 6 presets.

Say for instance that you have 2 turntables, each fitted with a different cartridge (most records sound best with an elliptical or VDH stylus but dynagroove cuts positively require a conical stylus). You can then assign one preset button to each turntable, each with its own optimum loading and gain.

Now imagine that some of your most precious historical records are mono, vertically cut with obviously a non-RIAA curve. You can then assign yet another preset to the same input, with the same loading and gain but with one channel's polarity inverted and mono on, and with the EQ that applies to these records.

As a final example, although the RCA/XLR selection is normally controlled using the toggle switches, it can be overridden. In the unlikely case that you have 6 sources you can assign one preset button each to the RCA and XLR pair of one input channel and hence use all 6 buttons to select between 6 sources. Note that crosstalk between RCA and XLR pairs of one input channel is not as low as between different input channels so you should not co-locate two sources that you expect to be putting out signal at the same time.

The Mola Mola Remote app

The control app for your Kula is available in the [Apple App store](#) and [Google Play store](#). The app will attempt to contact your Kula and should find it as long as it is within reach and plugged in. Also ensure that the Bluetooth function of your mobile device is enabled. The app will auto connect when there is only one Mola Mola device paired with the app. The app will turn the Kula on during the connection procedure when it is not already turned on. In case you have multiple Mola Mola devices select the device you wish to operate and click on Choose device.

First time setup:

1. Pull down to scan for devices (figure 5).
2. Click on the Add button of the device you want add (figure 6).
3. Type in new name and click Add device (figure 7).
4. Connect with device by clicking on Choose device at the bottom of the page (figure 8).

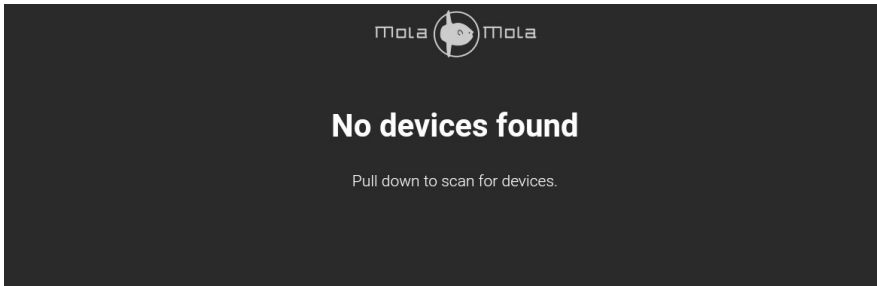

Figure 5: Pull down to scan for devices.

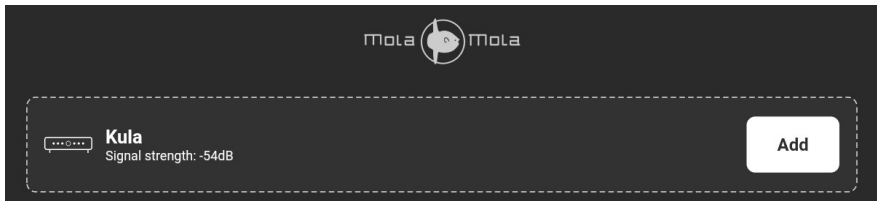

Figure 6: Discovered devices.

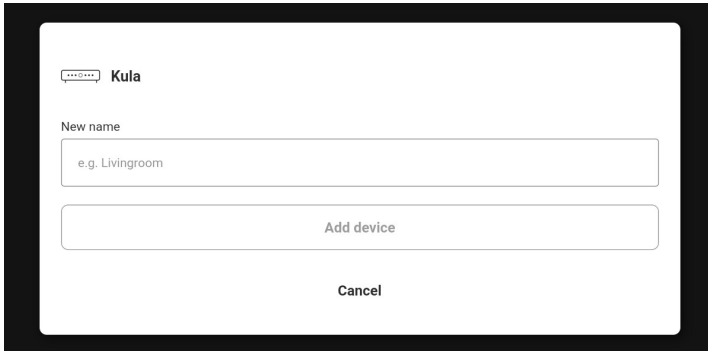

Figure 7: Type in new name and click Add device.

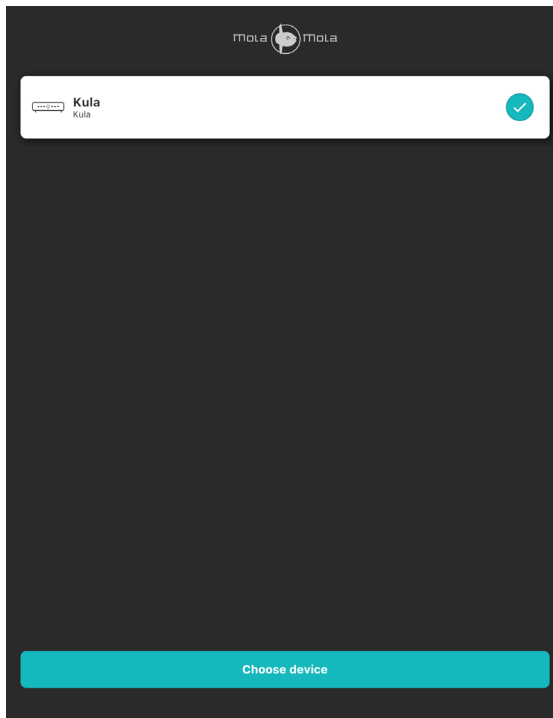

Figure 8: The start-up page.

Swiping a device to the left will allow you to remove the device from the Mola Mola remote app by clicking on the remove button. If the device is already connected with the app then an disconnect button is also shown here (figure 9).

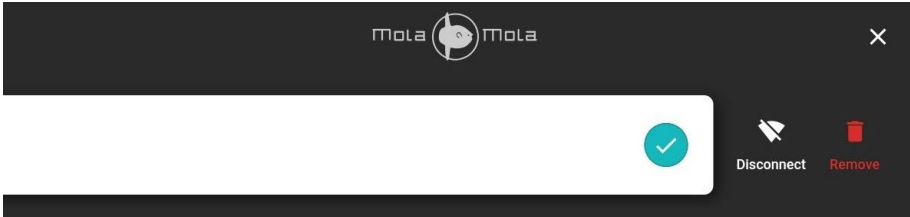

Figure 9: Swipe left to show disconnect and remove buttons.

Home Page

The home page is the regular remote control, as outlined in the section about basic operation. Move the slider at the bottom of the home page to change volume. The + and – buttons can also be used to adjust the volume in small steps. Click on the speaker indicator to mute or unmute.

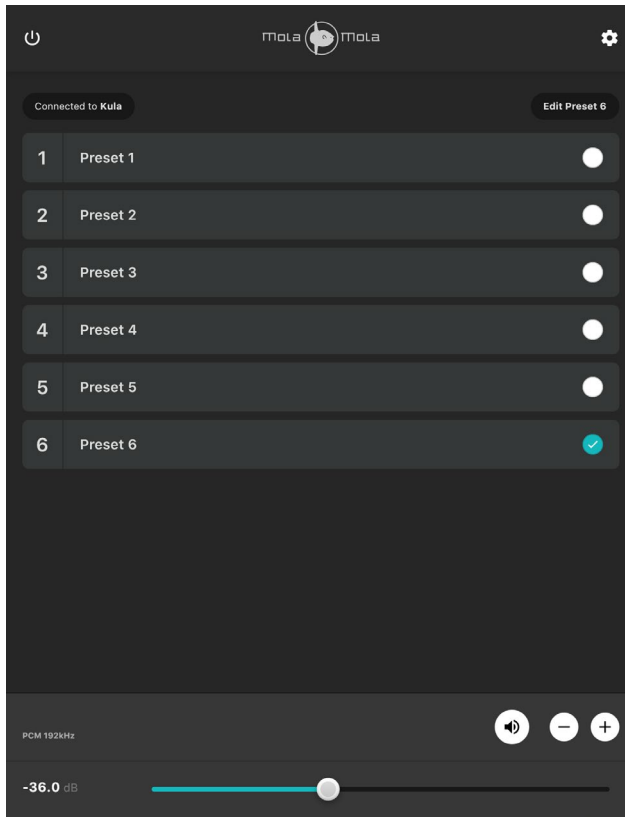

Figure 10: Home Page, Preset 6 is selected.

To program a preset, tap the button of the preset you want to change and click on the edit preset button in the top right corner.

Status DAC

If a preset with a digital input is selected, the status of the DAC will be shown above the volume bar on the home page. Input type shows the incoming audio format, PCM or DSD. Sample rate shows the sample rate of the incoming audio.

Preset Page

Here you can select the input channel and whether the XLR or RCA inputs are to be used. Usually you will want to leave the latter option at “switch” so that the toggle switch on the rear panel controls this.

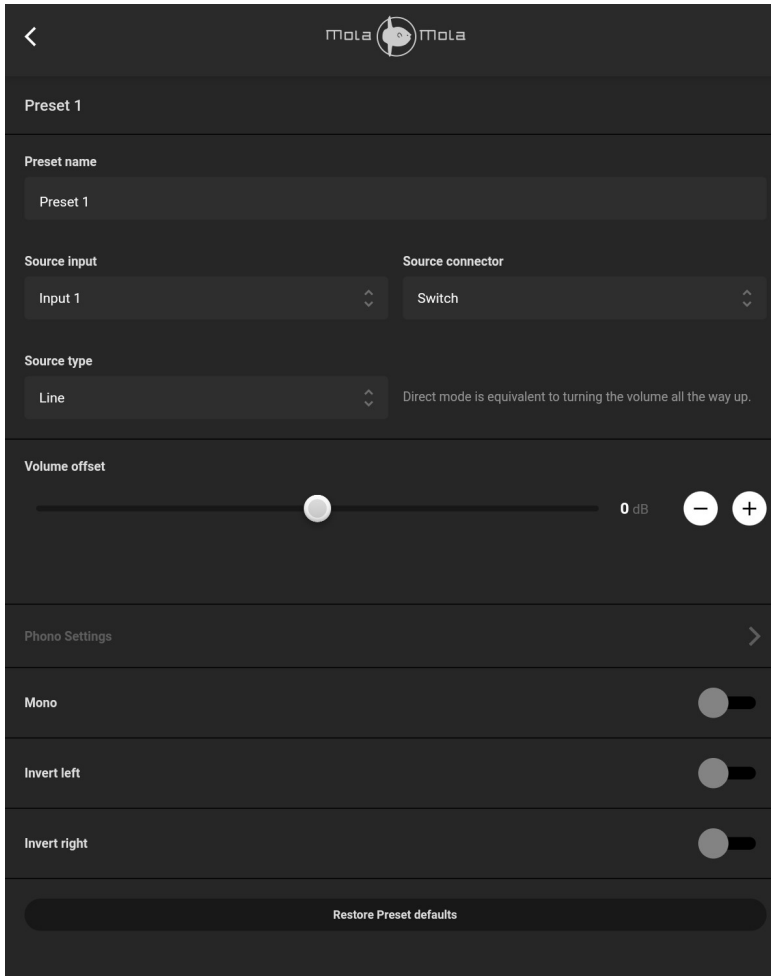

Figure 11: Preset Page, input 1 is selected.

You can edit the name of the preset. Wait until the check appears in the right corner of the Preset name field. The new name will automatically be shown on the home page buttons.

There are three types of analogue sources: **Line**, **Phono** and **Direct**.

Line is the normal kind of input.

Selecting **Phono** routes the signal through the phono stage. The configuration of the phono stage is done on another page, see further.

CAUTION: Only select Phono if the selected input is connected to a phono cartridge. Do not select phono if you are using an external phono stage. An external phono stage is a line source. Selecting Phono when a line source is actually attached to this input can potentially damage the phono stage.

Direct routes the input directly through to the input of the amplifier and disables the volume control. Direct mode should only be used when the source is itself volume controlled. Normally speaking the only use for Direct mode is connecting a surround sound processor when you want to use your stereo system as front left/right in a combined home theatre / hi-fi system. In order to signal that Direct mode is engaged, the power LED on the front panel will turn off (become red) while the LED above the active preset remains on. Direct mode is not available when a digital source has been selected.

CAUTION: Absolutely only select Direct if the source is volume controlled. Direct mode amounts to making a direct connection between the source and the power amplifier. It is also nearly equivalent to turning the volume all the way up. Engaging Direct mode with a source that is not volume controlled may damage your loudspeakers.

If you have the DAC option fitted, five digital sources will be listed as well, AES/EBU, optical, USB, network (Roon) and Bluetooth. These correspond to the four connectors on the DIGIN option panel on the rear of the integrated amplifier.

Level offset adds a fixed amount to the volume whenever this preset is active. Use this when you find that you always have to turn the volume up or down compared to other sources.

Mono does what you'd expect: sum left and right together.

The two **polarity invert** buttons invert the polarity (absolute phase) of the left and/or right channel. Inverting one channel is usually not useful, except when playing back vertically cut records which, played back with a modern cartridge, produce out-of-phase left and right. Otherwise, do not invert only one channel. Inverting both channels is occasionally useful if you happen to know that your source has inverted polarity or follows the now-

obsolete pin-3 hot wiring scheme. Note that the sonic effect of this is exceedingly subtle so when in doubt, simply leave those two buttons off.

Pressing the **Restore Preset defaults** button will only restore the current preset to its default settings. Global settings such as Mastering mode and balance will not be changed.

About Page

Clicking on the gear symbol in the top right corner of the home page will direct to the About page.

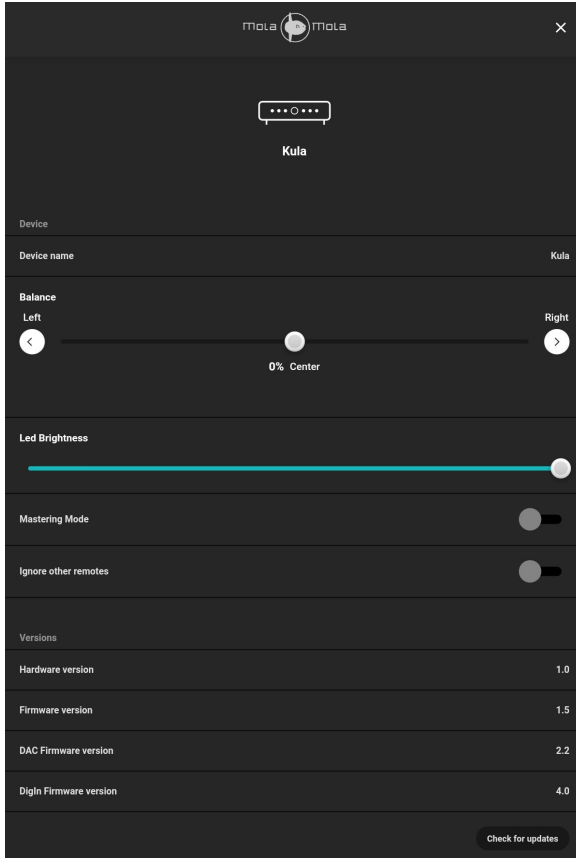

Figure 12: About Page.

Balance is not normally needed unless an acoustic oddity or asymmetrical speaker placement consistently pull the sound stage off centre. If you only have a consistently off-centre image with a phono source it is better to readjust your phono cartridge rather than using the balance control.

The **LED Brightness** of the preset LED and the power LED is user adjustable with front firmware version 1.5 or higher. The LEDs are set to maximum brightness by default. The LED brightness slider has 4 positions. Sliding the slider completely to the left will turn off the preset LED and the power LED is set at minimum brightness.

Use **Mastering Mode** if you want to perform A/B testing. If this mode is selected the switching time when changing presets is minimal. Select XLR or RCA as Source Connector on the Preset page to ensure that the switching time is as short as possible. In case the DAC option is fitted, the DAC will be kept locked with the last used digital source when switching to a preset with an analogue source.

When **Ignore other remotes** is enabled then the Kula will not respond to IR remote commands that are preceded with IR device address 16. The Kula will only respond to IR remote commands that are preceded with IR device address 19. This can be useful when the Kula responds undesirably to an IR remote control of another device. The Premium IR Remote and the Standard IR Remote both use IR device address 16. The Kula will not respond to those IR remote controls when Ignore other remotes is enabled.

Click on the **Check for updates** button to check if there is new firmware available. When there is an update available an update button and information about the update will appear. Clicking on the Update button will direct you to the update page (see figure 13) that will guide you through the update process.

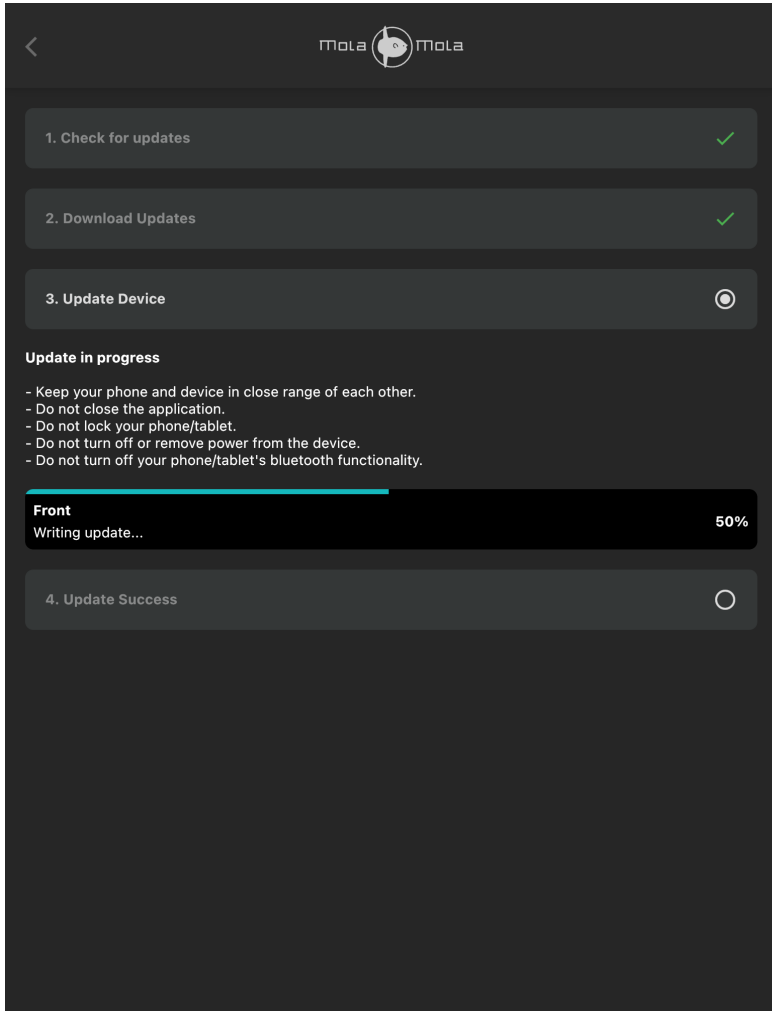

Figure 13: About Page.

Setting Up and Controlling the Phono Stage

If you marked the source as Phono, clicking on phono settings on the source page will land you at the **Phono settings** page. Changes made to the phono setup only effect the selected preset.

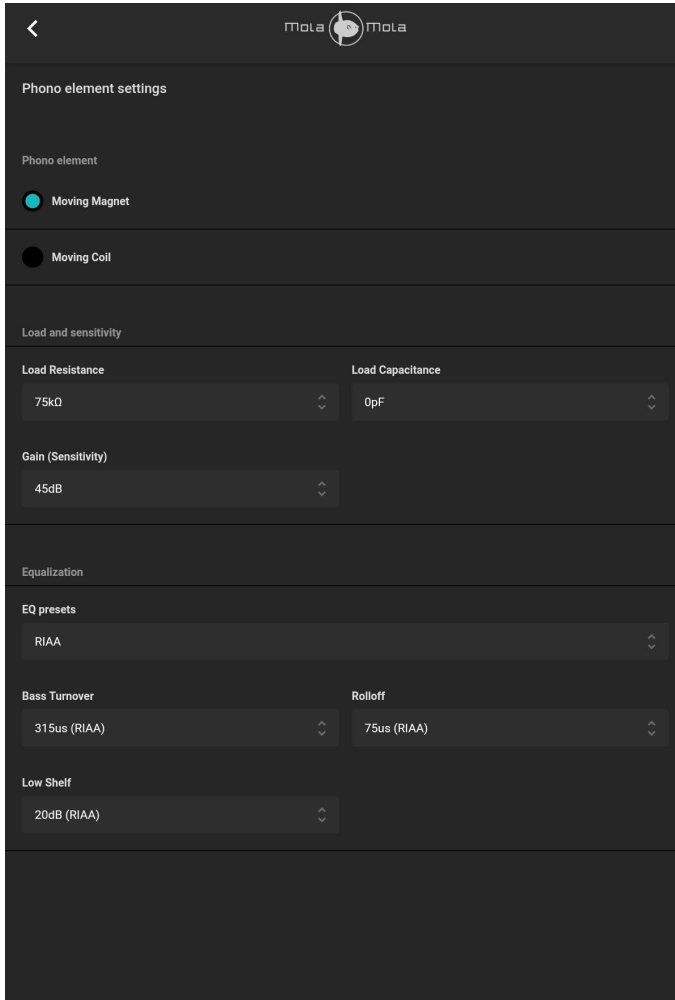

Figure 14: Phono Stage Page.

MM/MC selection

In order to ensure maximum sonic transparency, the phono stage has separate Moving Coil (**MC**) and Moving Magnet (**MM**) input stages, in contrast with most other phono stages that simply add a gain stage in MC mode.

After choosing between MC and MM, find the correct load resistance and in the case of MM, load capacitance too.

Termination and Sensitivity of MC Cartridges

Moving Coil elements have a low output voltage but also an extremely low output impedance, meaning that excellent signal-to-noise performance can be had with an input optimized for voltage noise. Another side effect is that there is no need to adjust load capacitance. Some cartridge manufacturers insist that even load resistance is uncritical, but we decided to add a selection of common load resistances nonetheless. These are in the **R** dropdown box. On the downside, sensitivities of MC cartridges are all over the place, so the **sensitivity** of the phono stage needs to be adjustable over a fairly large range. The documentation of your phono cartridge will give an indication or recommendation but by all means feel free to experiment around with sensitivity and load resistance.

Termination and Sensitivity of MM Cartridges

Moving Magnet cartridges have a fairly high output voltage but also an extremely high output impedance, in particular inductance, meaning that the input stage has to be optimized for current noise. Also both load resistance and capacitance are critical to get a flat response without droop or peaking. The documentation of your phono cartridge should list the optimum loading, which is to be taken pretty much as law, not as a mere recommendation. In the **R** dropdown box, select the value closest to the value given by the manufacturer. Then, look up the capacitance of your phono cable and subtract that value from the phono cartridge manufacturer's specification. Set the **C** dropdown box to the value closest to the result. When you have to choose between rounding down or up, keep in mind that a higher C results in more chiseled highs and a lower C in a more rolled off but more controlled and detailed upper octave. Leaving **Sensitivity** at the default 5mV is usually right. This is as far as most phono stages, including external ones, would ever go. The next part is for serious vinyl fanatics with extensive collections of historical records.

EQ Curves

In the early days of vinyl (and certainly shellac) almost every record label had their own EQ curve. Oddly enough they sometimes kept them secret in an early attempt at vendor lock-in, to force music lovers to buy their record player from the label's parent company. History records that the incompatibility wasn't even noticed by the punters so by 1956 most labels were happy to standardize on the curve now known as RIAA. As stereo only came about in 1958, a rule of thumb is that **the vast majority of stereo cuts were made using the RIAA curve.**

Almost all of those historical EQ curves are a combination of a manageable number of time constants which is why it turned out to be feasible to support switchable EQ in the analogue domain.

The **EQ** drop-down box lists all combinations of record labels and periods that we could obtain EQ data of, courtesy of Russell Fischer (www.shellac.org) and Larry Robinson (midimagic.sgc-hosting.com). If you can identify a particular record by its label, just pick the corresponding option and the numbers in the remaining four boxes will be set correctly. If you can't find data, you'll have to dial the numbers by ear.

Shelf sets the low shelf. Decrease it if you perceive the bottom end as too thundery or rumbly. Try increasing it if the bass lacks "authority".

T1 sets the bass turnover point. Increase the time constant if the sound is too woolly, decrease it if the sound is too thin.

T2 sets the treble roll-off. Increase the time constant if the sound is edgy, decrease it if it lacks bite.

We are aware of customers using these settings as a kind of tone control. This is fine of course.

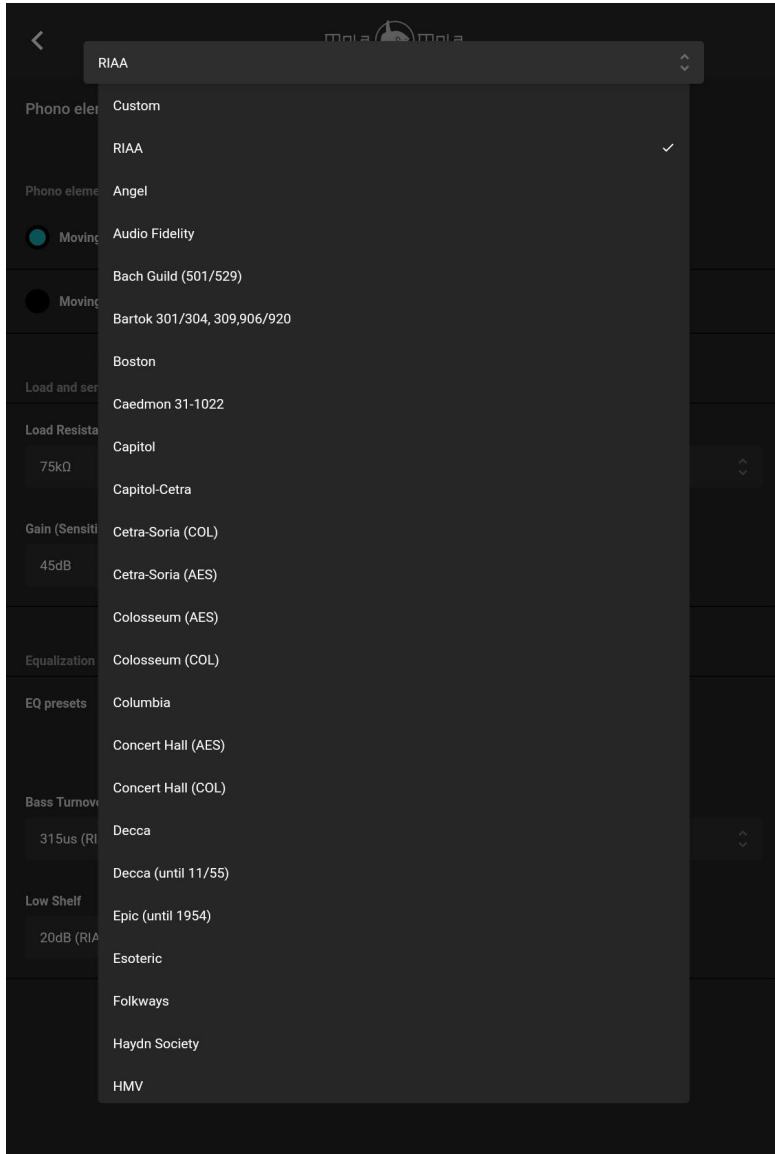

Figure 15: List of Phono Stage EQ Curves.

Roon

The Kula is a Roon Ready device if the DAC module and network module are fitted. The device volume in Roon is linked to the analogue volume control of the Kula.

The Kula supports convenience switching. If you press play in Roon and the selected preset in use does not have network as the source input, then Kula will switch to the first preset with Roon that can be found. If there are no presets with Roon as input, then preset 6 will be configured for Roon. After selecting a preset with Roon playback will start automatically.

The Kula also supports standby mode in Roon. The Kula will remain visible in Roon even when it is in standby mode. Pressing play in Roon will wake up the Kula from standby mode and playback will start automatically after a few seconds. You can also configure the auto sleep mode on the device setup page in Roon. This feature will automatically set your Kula in standby shortly after the music has stopped playing.

First time use

Before you can use the Kula in Roon, it must be enabled first. To do this go to Settings and then select the Audio page. The Kula will show up within a minute after powering up as a Roon Ready device (figure 15). Click on enable and give it a name of your choosing (figure 16).



Figure 16: The Kula will show up on the Audio settings page in Roon



Figure 17: Fill in Zone Name

Select Kula as the audio zone and then you can start playing your music.

Network update

Updating of the Network module is done via the Kula webpage. You can visit the Kula webpage via Device Settings page in Roon. Click on the information symbol and then click on Configure Device (figure 17).



Figure 18: Click on Configure Device to go to the Kula webpage

Or you can enter the IP address in your browser. The IP address of the Kula is visible under Audio Device in Zone Settings or on the Audio settings page.

If there is a update available a update button is visible in the Kula webpage.

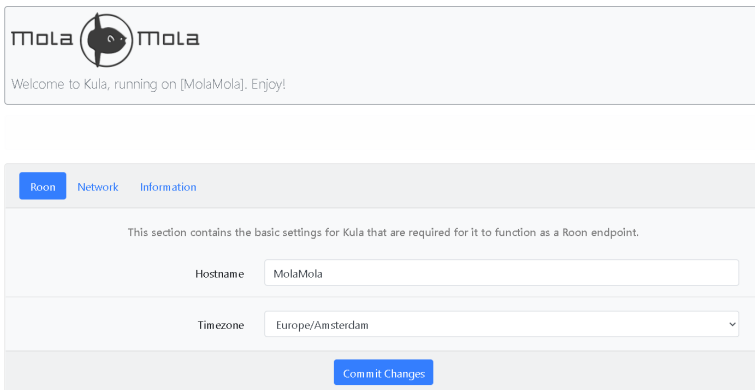

Figure 19: The Kula webpage

DAC

The DAC option contains 5 digital audio inputs: USB, Optical (Toslink), AES/EBU (XLR), Network and Bluetooth (SBC, AAC, APTX, LDAC).

The supported formats are shown in Table 3.

Only the USB and Network inputs support the playback of DoP (DSD over PCM) and Native DSD. Native DSD is not supported with the Mola Mola USB-Audio Driver for Windows.

MQA is not supported.

A resync delay of 1 second is recommended for playback of DSD files.

#	Function	PCM support	DSD support
1	USB type B	Up to 384 kHz / 32 bits	DoP: up to DSD256 Native: up to DSD256
2	Optical (Toslink)	Up to 192 kHz / 24 bits	No
3	AES/EBU	Up to 192 kHz / 24 bits	No
4	Network	Up to 384 kHz / 32 bits	DoP: Up to DSD256 Native: Up to DSD256
5	Bluetooth	48 kHz / 16 bits	No

Table 4: Digital source overview

Drivers and Updates

XMOS driver

To play audio from a Windows computer via USB, you have to install a XMOS driver. The XMOS driver is available for download on the Mola Mola download page (www.mola-mola.nl). MAC and Linux devices do not need this driver.

Firmware update

The DIGIN module and the PWM DAC module contains firmware which can be updated. The update tool is available for download on the download page of Mola Mola: (www.mola-mola.nl). This update tool is available for Windows-7 and up and Max OS 10.6 and up. How to update is described in the help file of the update tool. Before starting the update tool, make sure that the selected source is USB.

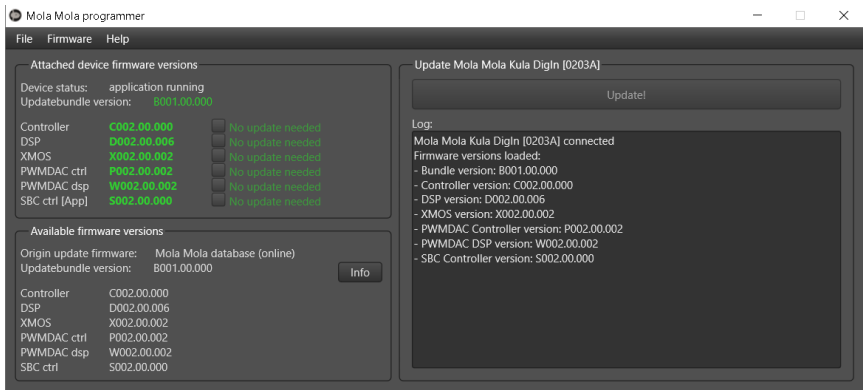

Figure 20: Firmware update tool.

Troubleshooting

Most difficulties in audio systems are the result of incorrect connections, or improper control settings. If you encounter problems, isolate the area of the difficulty, check the control settings, determine the cause of the fault and make the necessary changes. If you are unable to get sound from your device or its behaviour is not as expected, refer to the suggestions for the following conditions:

No response when pushing buttons: Verify the mains connection. Unplug the power cable from the integrated amplifier and try to power another device with it. If this works, check the fuse. Lever out the little drawer underneath the mains input and replace the fuse that is hooked into the end of it. The second fuse that you see in a separate cavity of the fuse drawer is a spare. If the device still does not work, contact your local retailer. The device may need repair.

The device responds (as witnessed by lights and clicking relays) but no sound: Verify that the toggle switch on the input is correctly set (RCA or XLR). If you have chosen to override it using the Mola Mola remote app, verify the setting. Ensure that the source is connected to the selected input. This may have been re-routed using the Mola Mola remote app. When in complete doubt, restore the factory preset by holding down the middle two buttons for more than one second. Note though that this erases any programming you may have done, including phono settings.

Loud and distorted sound even at low volume settings: a line level source is routed through the phono stage. Connect the source to another input or reconfigure the input as a line input using the Mola Mola remote app.

The volume control has no effect and the power LED is off although one of the preset LEDs is on: you have selected a preset that is programmed as Direct. If indeed you have a volume controlled device like an A/V receiver connected, this is the intended behaviour and you may have simply selected this preset by accident. If you have no volume controlled source, reprogram this preset as a normal input before you continue using the product.

The music drops out: Upsampling of audio to high samplerates might trigger the DSD detection algorithm causing dropouts. To prevent this set Headroom adjustment to -6dB in Roon.

Kula is not shown in Roon: The Roon Core and the Kula must be connected to the same network. Roon Ready functionality is only applicable if the PWM DAC module and network module are fitted.

Audio performance data

Item	Symbol	Min	Typ	Max	Unit	Notes
Max output Power	Pr, 4Ω		190		W	0.0004% THD+N
	Pr, 8Ω		100		W	0.0004% THD+N
Max output Power	Pr, 4Ω		300		W	1% THD+N
	Pr, 8Ω		150		W	1% THD+N
Max input level	Vin		20		dBu	(7.75 Vrms)
Input sensitivity	Vin		1.4		Vrms	Analogue inputs
Input impedance	Zin		100k		Ohm	
Output Impedance	Zout			7m	Ohm	20Hz - 20kHz
Gain range			-70 - +15		dB	
Gain resolution			0.2	1	dB	Better than 0.2 dB over normal listening range
Signal-to-noise ratio	SNR		113		dB	Unweighted
Bandwidth	BW	5		50k	Hz	+0/-3dB

Table 5: Audio Performance Data

Audio performance data Phono Stage

Item	Symbol	Min	Typ	Max	Unit	Notes
Input noise (MC)				0.35	nV/rtHz	
Input noise (MM)				2.8	pA/rtHz	
Sensitivity		30		5000	μ V	
Distortion (THD, IMD)	THD IMD					Not measurable using current test equipment, number is an estimate based on performance of the discrete gain block at maximum signal level
RIAA conformance				0.1	dB	

Table 6: Audio performance data Phono Stage

Audio performance data DAC

Item	Symbol	Min	Typ	Max	Unit	Notes
Output level	Vout			20	dBu	
Signal to Noise Ratio		130			dB	
Bandwidth				80	kHz	
Distortion (THD, IMD)	THD IMD			-140	dB	Not measurable using current test equipment, number is an estimate based on performance of the discrete gain block at maximum signal level
Integrated jitter				1 300	Ps fs	From 10Hz upwards From 1kHz upwards
Jitter rejection		80			dB	At 1Hz after 20 seconds of lock

Table 7: Audio performance data DAC

Technical data

Item	Value	Notes
Supply voltage	90-135 / 180 – 270 Volt AC/47-63Hz	Auto Switching
Power Consumption	< 4 Watt (low power mode, wake on LAN) 390 Watt (max power)	
Dimensions	435mm*110mm*340mm	(W x H x D)
Weight	9 kg	
Fuse	T6,3A 250V 5x20mm ceramic	

Table 8: Technical Data

Annex I: RC5 Codes

The IR device address is 19.

The Kula also responds to commands preceded with IR device address 16. You can disable that the Kula responds to IR device address 16 by enabling Ignore other remotes on the about page.

Command	Primary Code	Alternative Code
Mute	12	53
Volume Up	16	51
Volume Down	17	52
Presets 1...6	1...6	
Power on/off		50
Next Source		54
Previous source		55

Table 9: RC5 Codes

10 consecutive repeats (no change in the T bit, i.e. holding the button depressed) of Mute or 1...6 powers the device down.

Annex II: Standard Remote Control Unit

Button	Function	Notes
1	Mute, ON/OFF	Short press: Mute / Unmute / ON. Long press: OFF
2	Volume UP	Subsonic ON/ OFF when remote is programmed for Lupe (device address 21)
3	Volume DOWN	Mono ON/ OFF when remote is programmed for Lupe (device address 21)
4	Source UP	
5	Source DOWN	

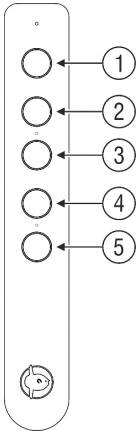

Programming

The device address of the Standard Remote can be programmed to a default or a device specific device address. Hold button 1 and 5 simultaneously until the LED starts blinking. The number of consecutive blinks corresponds to the device address:

1. Default / Legacy / All devices (device address 16)
2. Makua (device address 17)
3. Kula (device address 19)
4. Tambaqui (device address 18)
5. Lupe (device address 21)

Press button 4 or 5 to scroll up or down through the device addresses. Press button 1 once the correct device has been chosen. The device has now been selected. Check the “ignore other remote” option in the app to have the device respond to the device specific device address only.

Replacing the batteries

Place the remote control upside down on a hard surface. Be careful not to scratch it.

1. Unscrew both screws with a Phillips screwdriver.
2. Carefully remove the aluminium cover. Make sure the PCB stays in place.
3. Carefully remove the AAAA (LR8D425) batteries (1.5V Alkaline).
4. Place the new batteries. Mind the polarity!

Replace only with the same type of batteries or equivalent.

5. Reposition the aluminium cover and fasten the screws.

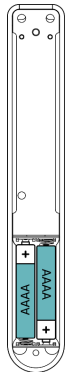

Revision History

Revision	Description	Date
R0	Initial draft	20-03-2020
R1	First release	01-10-2020
R2	Added Restore preset defaults Added Ignore other remotes Added warranty disclaimer	18-12-2020
R3	Added remote control info	30-09-2021
R4	Added LED brightness info Added Fuse specification	02-01-2023